

MCT

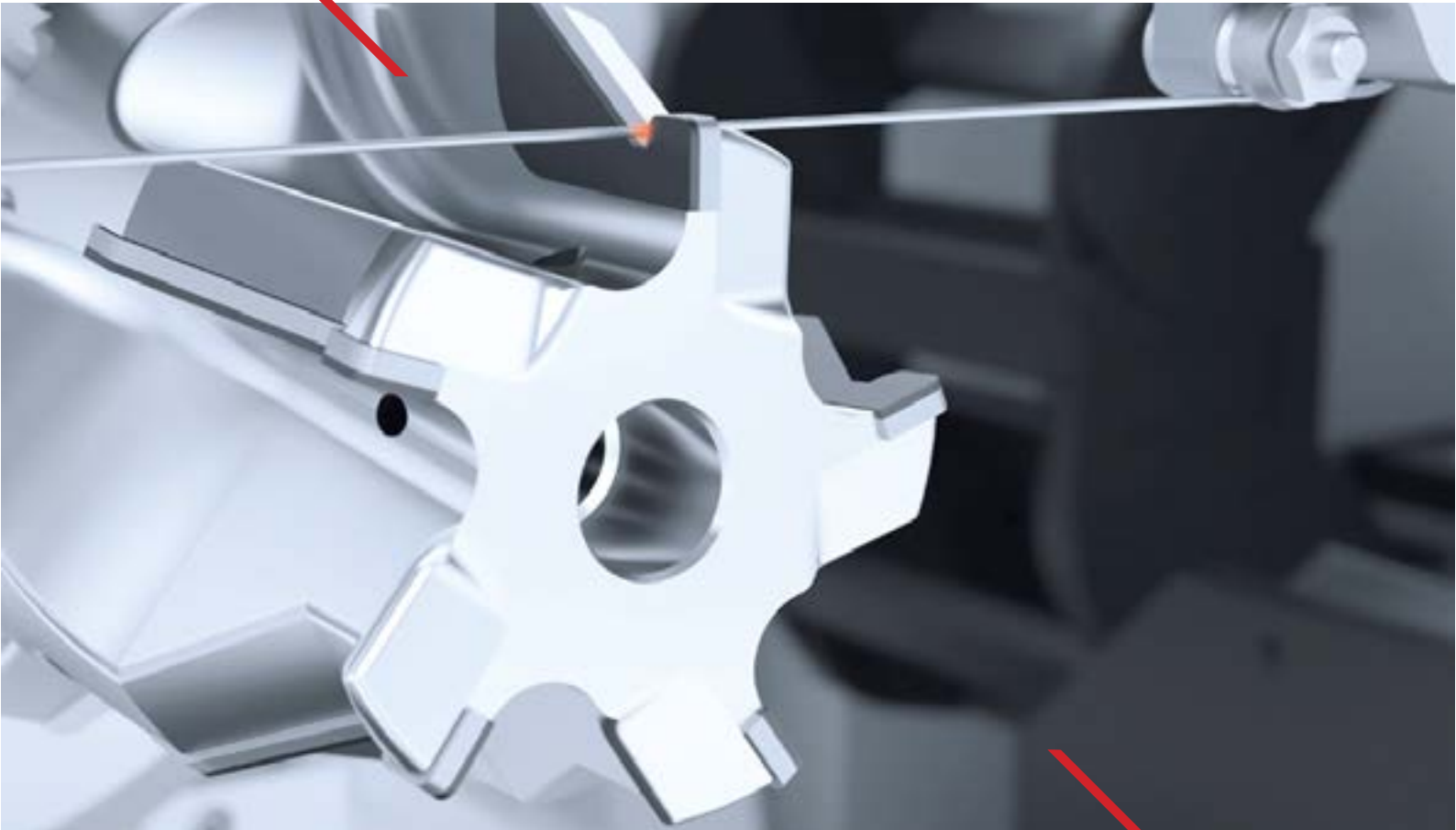

MICRO CONCEPT TOOLS

+91 9003065004 / +91 9840264036
microconcepttools@gmail.com / design@mct.in.net
www.mct.in.net



MCT

MICRO CONCEPT TOOLS CUSTOMERS



WELCOME to MICRO CONCEPT TOOLS

MICRO CONCEPT TOOLS was established on 2013 as a partnership concern (was 18 years in cutting tools experience - Design, Manufacturing and applications) and Trained in Germany / Swiss. We trained 100 years Technologies in German Company. MCT has Successfully Crossing 6yrs of rich experience in Design, Manufacturing all kinds of special combination PCD Reamers / PCD Inserts / PCD Milling Cutters ISO & Special Inserts boring bars / Micro Adjustable Boring Bar / Expandable Reamers / Run Out Compensation Holders / Customized Face Lock Holders / Special Turning Holders and etc...

MCT has earned sizeable reputation for meeting strict targets on Quality, Cost and Delivery (QCD) parameters. MCT uses latest German technology to keep itself abreast of the changing trends and offer Customers state of the art facilities and processes.

We are Successfully Crossing 500+ Projects... (Steering System Rack Housing, Gear Box, Starter Motor, Vacuum Pump Body, Manifold, Aerospace - Hydraulic Parts, Chain Cover, Pistons, Engine Block, Connecting Rod, Valves and Etc...)



M. SURESH KUMAR
(MANAGING DIRECTOR)



OUR MISSION

Our Mission is to be World Class Quality, On-time Fast Delivery and Cost Effective Tooling Solution provider for Auto & Non-Auto Segment as a Pioneer for all Tooling Solution with Humanity & Honesty



OUR VISION

To be in the list of First 5 Leading Tool makers in India Tooling Industry, as a Cost Effective Solution Provider with Win-Win Situation by Continuously upgrading on Technologies & Satisfy Customers as well as Our Team Members.



OUR STRENGTH

MCT Team consists of highly experience and dedicated persons comprising of young achievers and this give us edge over on our competitors. Our team never compromise in offering Quality, Time bound and Cost Effective components exceeding customers need expectations.

WHY MICRO CONCEPT TOOLS?

- ⚙️ Very Fast delivery Lead time for Project 5-10 Working days only.
- ⚙️ PCD Reamer Manufacturing
2 Micron Tolerance
- ⚙️ PCD Reamer Start \varnothing 3.5 - \varnothing 200 mm.
- ⚙️ PCD Reamer Supplied till Combination of 10 Steps.
- ⚙️ We are using Customized Laser Micrometer accuracy is 0.0001 mm with proper Static design balancing Software.
- ⚙️ Proper Dynamic Balancing - Germany Machine





QUALITY

Regarding the inspection equipment, we are using Video Measuring Machine to ensure the profile inspection.

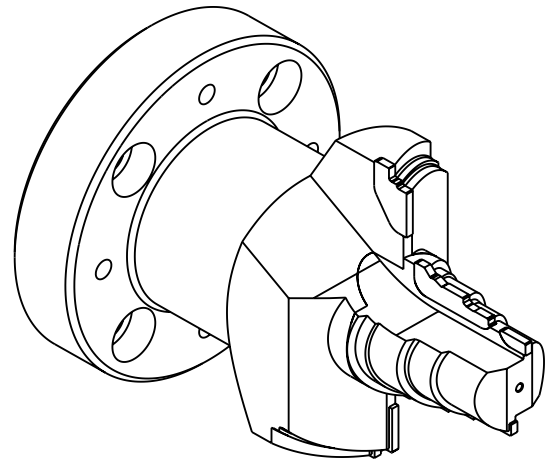



TECHNOLOGY

RESEARCH AND DEVELOPMENT

Micro Concept Tools is having very experienced designers and we are considering the cutting tools life and quality as the most important factors. "Designing is the key of Cutting Tools" which is our principle and pay full attention to every process of the tools manufacturing. Tool design complete with static balancing.



PRODUCTION PROCESS

Micro Concept Tools is following the principles as below

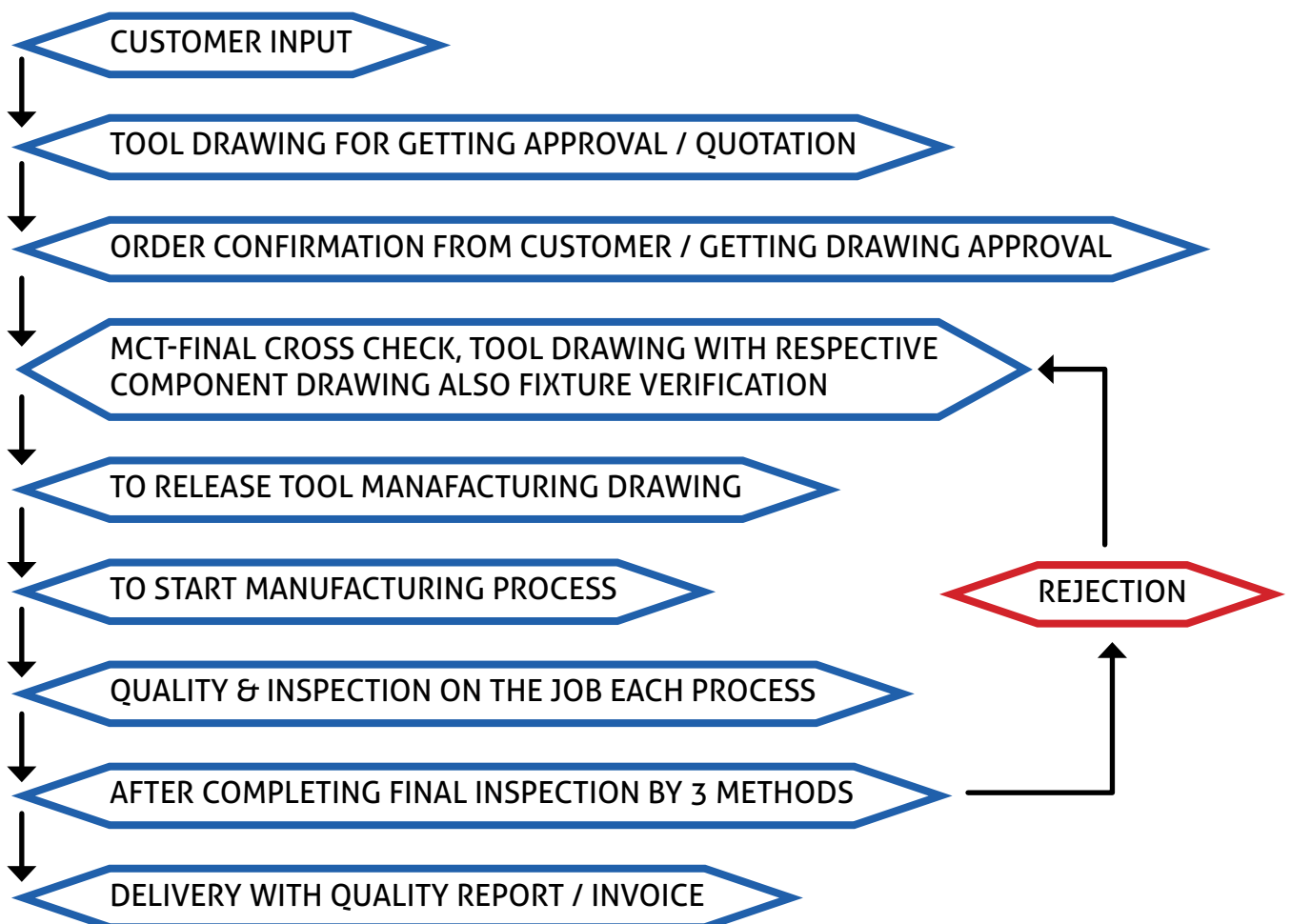

TOOLS

MANUFACTURING LINE

Sophisticated Machineries, measuring equipment's and allied equipment's are the key factors of manufacturing high precision tools.

Micro Concept Tools is specialized in all kinds of complicated PCD Tools manufacturing, designing, researching, and developing and after processing with high quality tools, reasonable price and hence we won the market and customer's heart.



DMG MORI

AKTIENGESELLSCHAFT

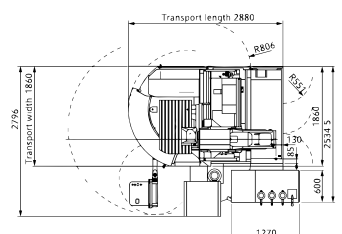
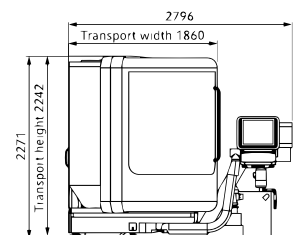



VOLLMER

QWD

Our Special thanks to Vollmer team for giving such a Wonderful Machine because of this machine we can able to achieve in 3 (Micron) Profile accuracy Run Out. Good Surface Finish helpful to increase PCD Tool Life.

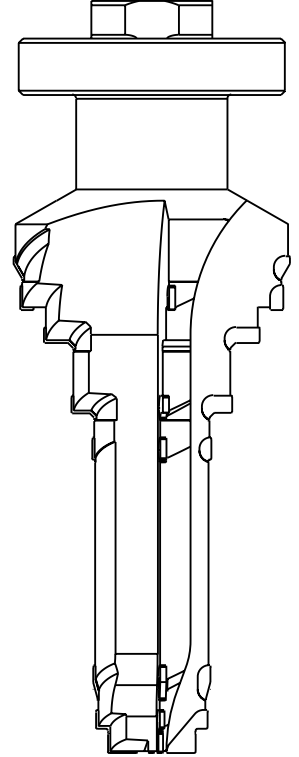

AGIE

250 SF + F HSS

Agie Wire cut machine is a fine finish and accuracy based machine. It works with safe and fine auto control of different wire base. It is fully automatic control with output of DC Power base. It operate with micron cutting jobs and multiple process of taper and aerospace cutting jobs etc., It helps MCT in PCD disk Projects and Carbide Projects.



WALTER

HMC

We re manufacturing Solid Carbide drills, End Mills Etc. Helices machines are able to measure complex cutting tools in a single chucking, including such features as rake angle, lead, helix angle, relief angle and even profile scan.

WALTER measuring machines also reduce set up time by accurately measuring your wheels before they go in the machine.



strausak

FLEXIMAT

Strausak an Swiss machine for carbide cutting tool manufacturing and sharpening equipped with a NUM control, which integrates the programming software. A new tool grinding center equipped with the latest generation of CNC control.





**CUSTOMIZED
GRINDING
MACHINE
(ACCURATE)
32000 rpm**



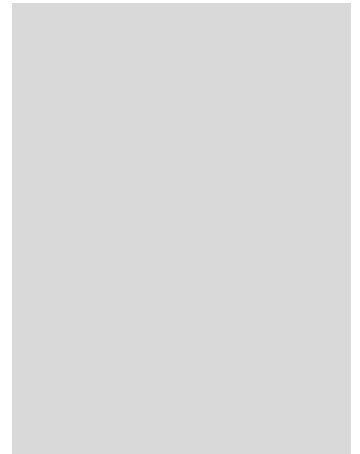

**NEW GEOMETRY / NEW TOOLS
RESEARCH AND DEVELOPMENT**



MAIN

PRODUCTS



To Survive by quality, to win the market by perfect tools and consider customer' satisfaction as the basic standard.



PCD REAMER



PCD REAMER



PCD CENTRECUT
COMBINATION REAMER



EXPANDABLE REAMER



PCD REAMER



MICRO ADJUSTABLE
BORING BAR



FACE MILLING CUTTER



PCD OD TREPPANNING TOOL



PCD GROOVING TOOL



INSERT TYPE BORING BAR



PCD ID GROOVING TOOL



PCD REAMER WITH ID GROOVING



BOARING BAR COMBINATION



PCD COMBINATION REAMER



DAMPENING BACK BORE TOOL



SHELL MILLING CUTTER



PCD DRILL



T SLOT MILLING CUTTER



INSERT TYPE COMBINATION BORING BAR



INSERT TYPE U-DRILL



MICRO ADJUSTABLE BORING BAR



INSERT TYPE TURNING HOLDER



INSERT TYPE BORING BAR



MICRO ADJUSTABLE BORING BAR



SOLID CARBIDE DRILLS



SOLID CARBIDE ENDMILLS



BALL NOSE ENDMILL



MILLING CUTTER



FACE MILLING CUTTER

PCD

INSERTS



OUR KEY CUSTOMERS



AUTHORIZED DISTRIBUTOR

NCT

NEO CONCEPT TECHNOLOGIES

2/281, Harini Arcadae, Edayarpalayam Road,
Vadavalli, Coimbatore - 641041. Tamilnadu
Contact Person - Mr.Anbarasu

Contact Number - +91-9894606630 / 9566855543



MICRO CONCEPT TOOLS

FACTORY ADDRESS

NO.221/2 & 221/2B1, SIDCO INDUSTRIAL ESTATE,
TIRUMUDIVAKAM MAIN ROAD, THIRUMUDIVAKAM,
CHENNAI-600 044, TAMILNADU, INDIA.

OFFICE / BILLING ADDRESS

NO.585, VASANTHAPURAM ROAD,
KAYARAMBEDU, GUDUVANCHERY – 603 202

+91 9003065004 / +91 9840264036
microconcepttools@gmail.com / design@mct.in.net
www.mct.in.net

